

with alternating current electric fan series AP

AP 830 EB

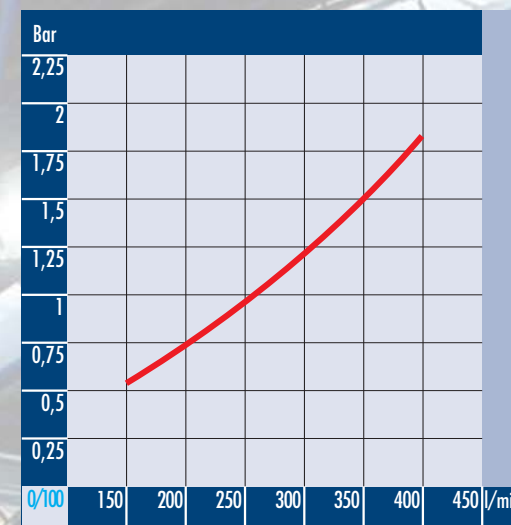
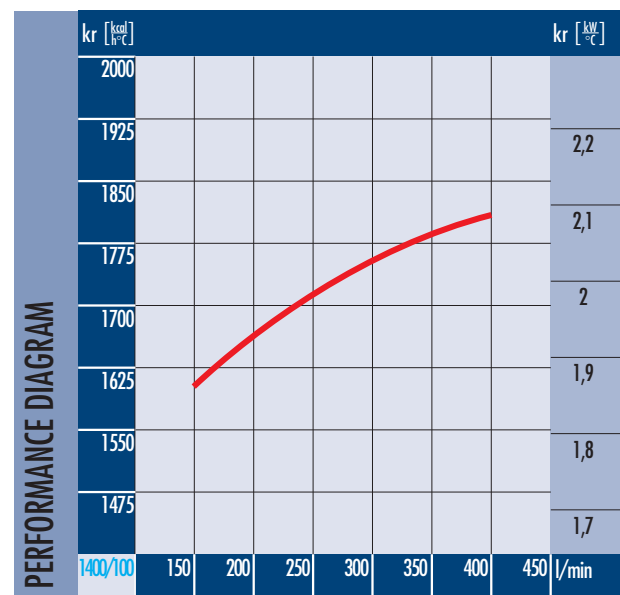

CORRECTION FACTOR

cSt	22	30	46	68	100	150	220
f	0,6	1	1,5	2,3	3,5	5	7

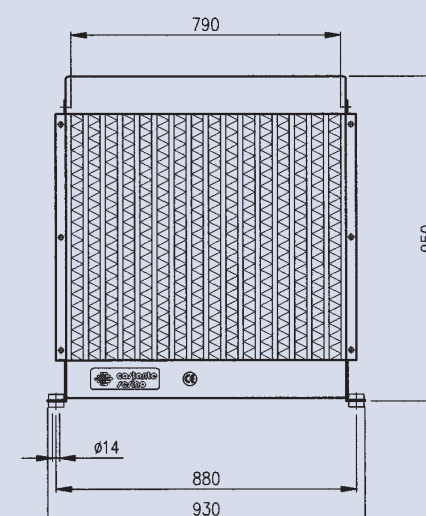
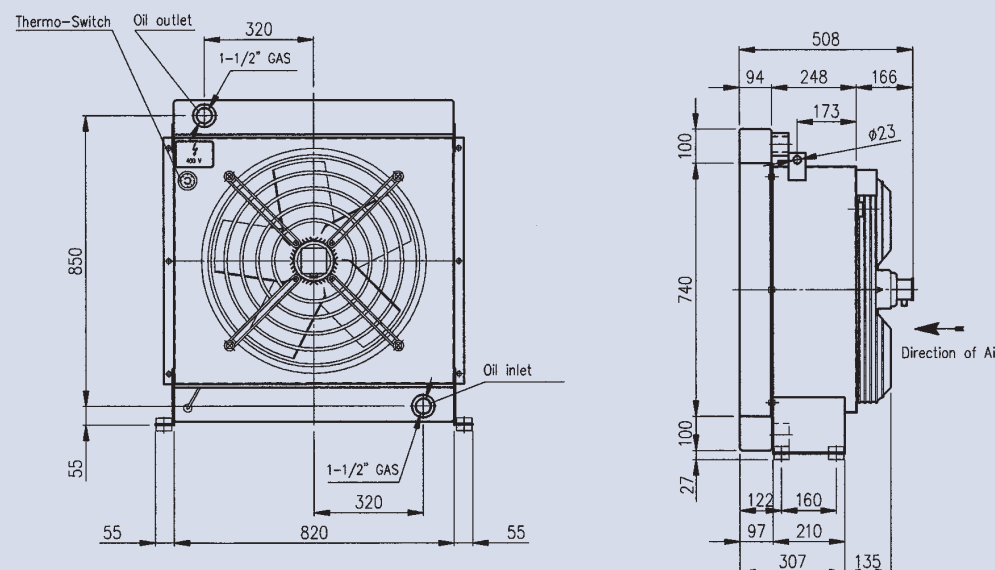

Dimensions and technical characteristics are not binding

Oil flow l/min	Capacity l	Voltage V	Frequency hz	Power W	Current A	Air flow m³/h	Protection IP	Noise Level dB(A)	Weight kg
150 - 400	20	230/400	50	900	2,6/1,5	9.500	55	73	83
upon request only		260/460	60	1150	2,6/1,5	11.500	55	75	

TABLE