

with alternating current electric fan serie AP

AP 680 EB

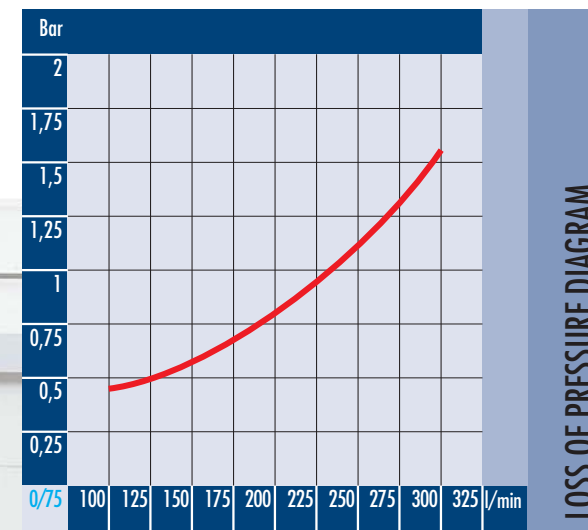
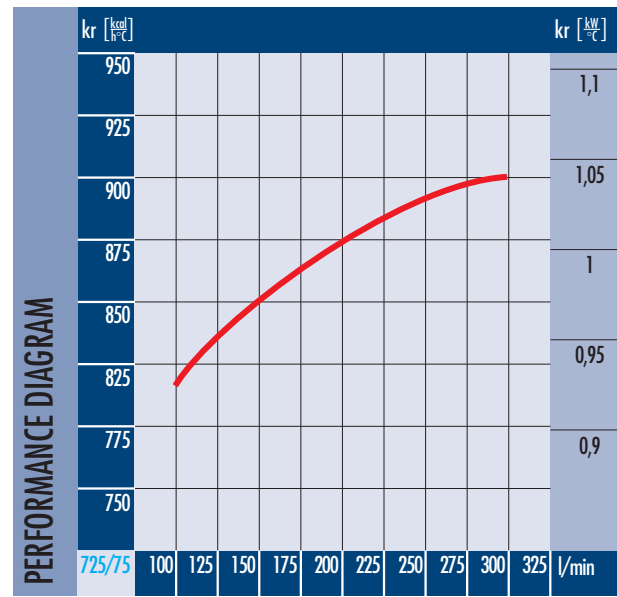

CORRECTION FACTOR

cSt	22	30	46	68	100	150	220
f	0,6	1	1,5	2,3	3,5	5	7

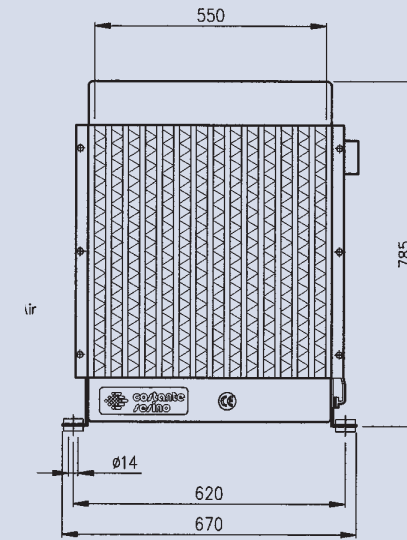
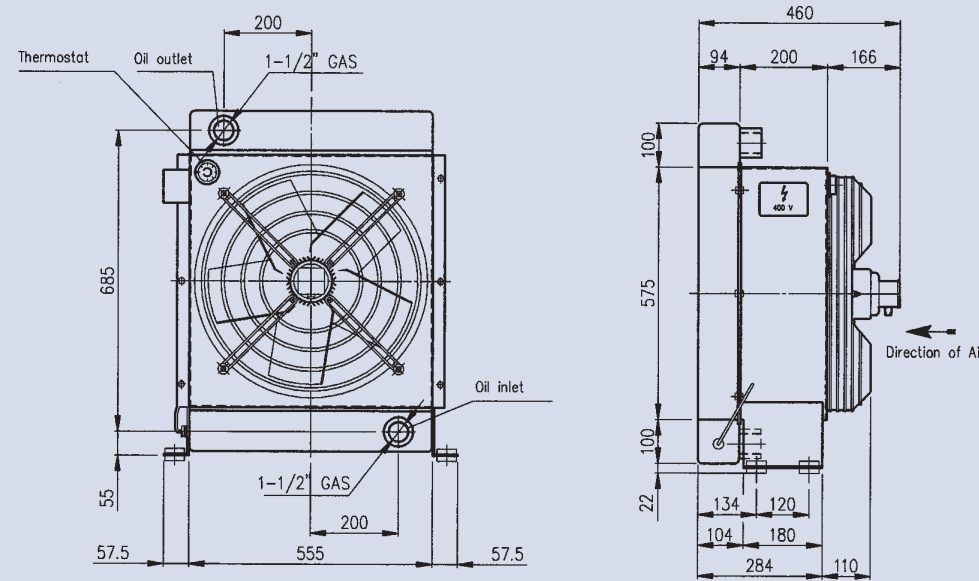

Dimensions and technical characteristics are not binding

Oil flow l/min	Capacity l	Voltage V	Frequency hz	Power W	Current A	Air flow m³/h	Protection IP	Noise Level dB(A)	Weight kg
100 - 300	15	230/400	50	560	2,46/1,42	6.300	55	72	62
		260/460	60	810	2,30/1,3	8.800	75		

TABLE