

with hydraulic motor fan serie AP

AP 430 I

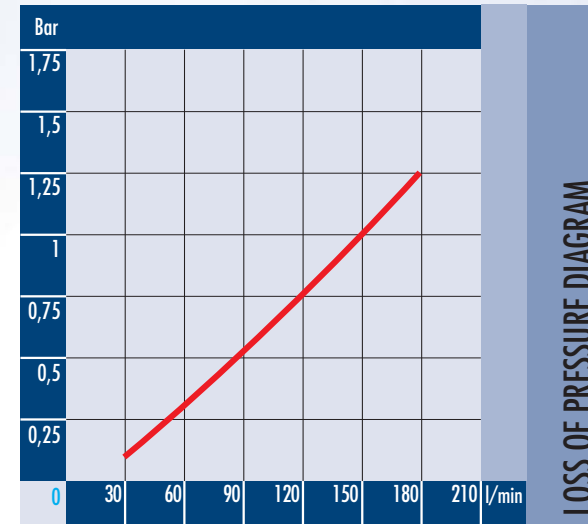
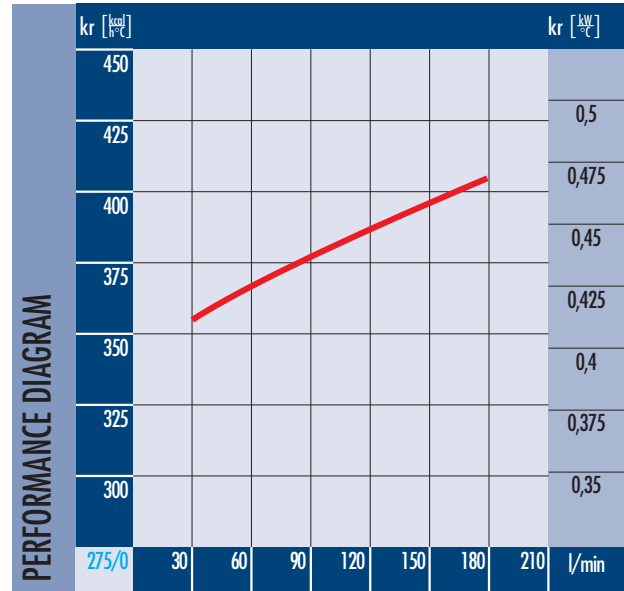

cSt	22	30	46	68	100	150	220
f	0,6	1	1,5	2,3	3,5	5	7

CORRECTION FACTOR

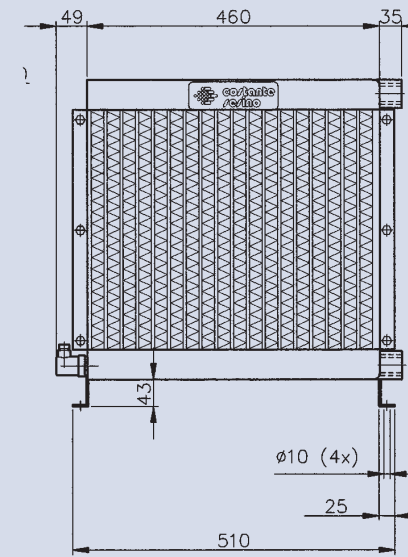
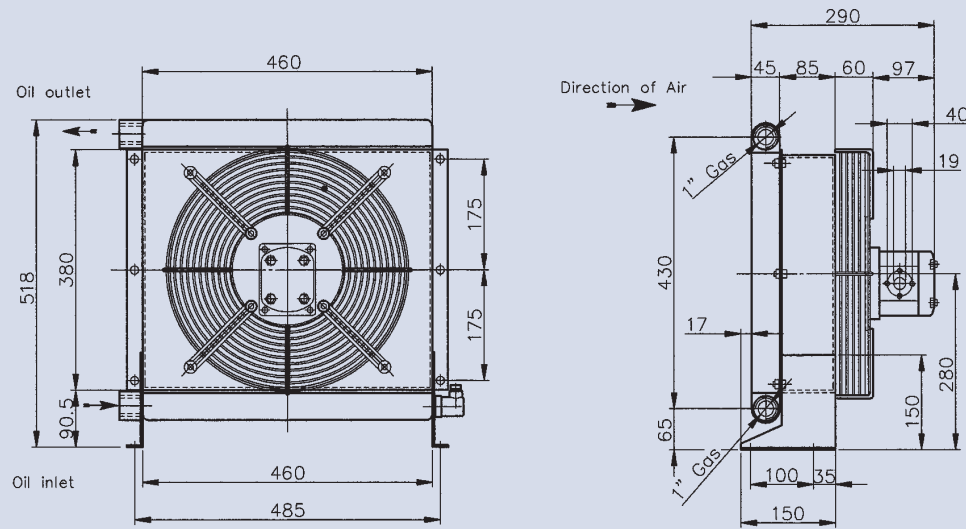

Dimensions and technical characteristics are not binding

Oil flow	Fan speed	Power	Displacement	Motor flow	Air flow	Noise Level	Weight	Capacity
l/min	rpm	W	cc/r	l/min	m ³ /h	dB(A)	kg	lt.
30-150	2.700	770	11,3	31	7.000	71	21	3,6

TABLE