

with alternating current electric fan serie AP

AP 2/830 EB

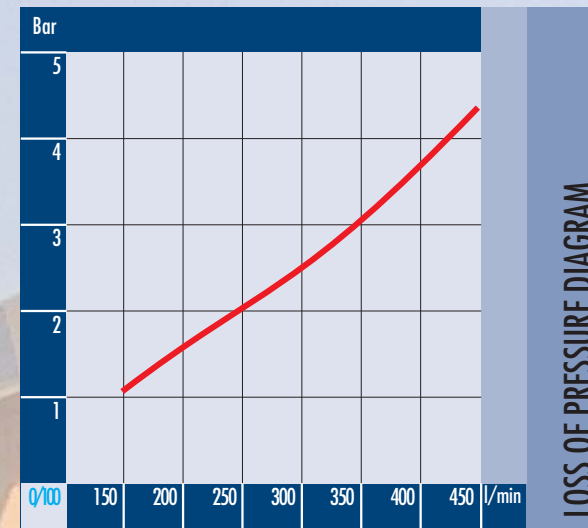

CORRECTION FACTOR		22	30	46	68	100	150	220
cSt	f	0,6	1	1,5	2,3	3,5	5	7

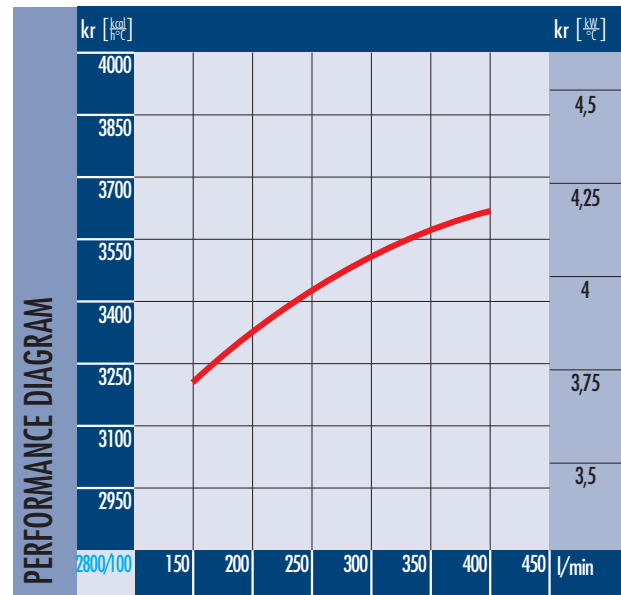
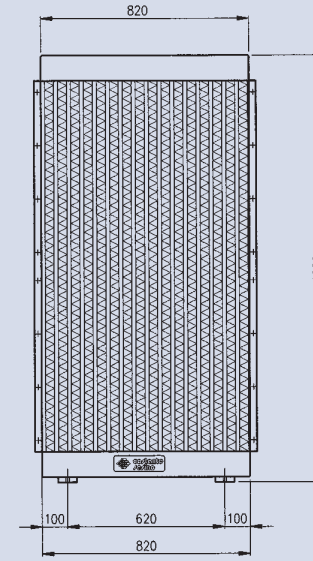
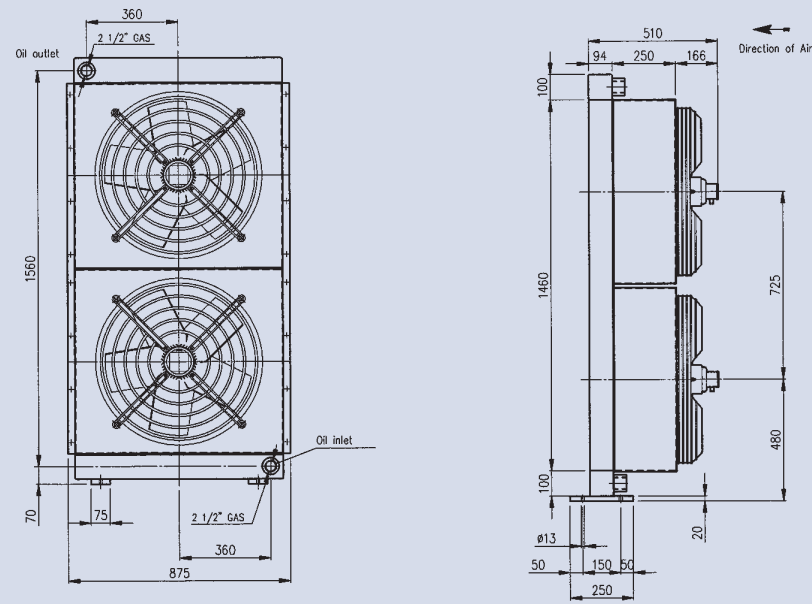

85



Dimensions and technical characteristics are not binding

Oil flow l/min	Capacity l	Voltage V	Frequency hz	Power W	Current A	Air flow m³/h	Protection IP	Noise Level dB(A)	Weight kg
150 - 400	40	230/400	50	2x900	2x2,6/1,5	2x9.500	55	75	180
upon request only		260/460	60	2x1.150	2x2,6/1,5	2x11.500	55	77	

TABLE